

# CONTROL KNOBS:

## "F" SERIES -

AVAILABLE WITH / WITHOUT WHITE INDICATOR

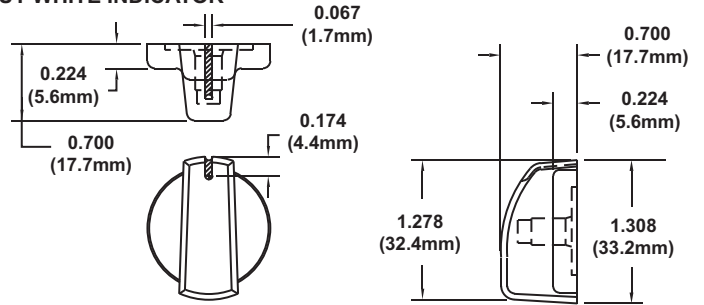
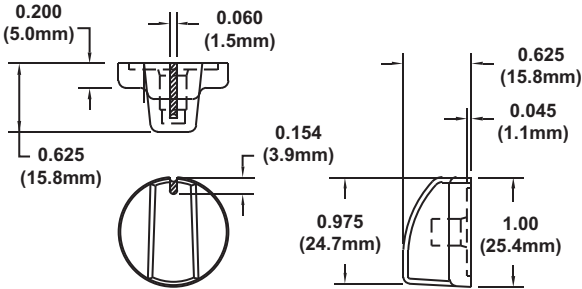

PART NO.	DESCRIPTION
01-1054 (DF51)	.187 X .156 +/- .003 (.187 SPRING DIAMETER)
01-1055 (DF51)	.252 X .160 +/- .003 (.250 SPRING DIAMETER)

PART NO.	DESCRIPTION
01-1056 (CF51)	.187 X .156 +/- .003 (.187 SPRING DIAMETER)
01-1057 (CF51)	.252 X .160 +/- .003 (.250 SPRING DIAMETER)
01-1057A	.252 x .221 +/- .003 (.250 SPRING DIAMETER)

INSERT TOOLING: FOR OTHER SHAFT SIZES UPON REQUEST

### INDEX NUMBERS

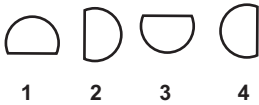

An Index number (above) when looking at the end of the switch shaft. Must be added to the knob part number when Indexing is required.

EXAMPLE: For "01-1054" knob with index number "1" . part number will be "01-1054-1"



01-1054-1

MATERIAL - BLACK ABS



## SWITCH PLATES & NUT COVER:

### P.N. 04-1005

AIR / TEMP SWITCH PLATE

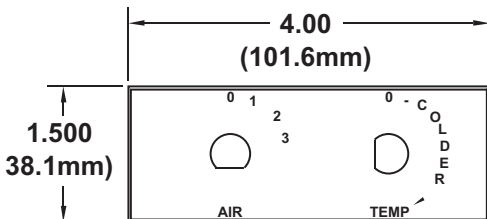

### P.N. 04-1010

FAN / TEMP SWITCH PLATE

2.58 (65.5mm)



### P.N. 04-1659

NUT COVER



FRONT VIEW

BACK VIEW



NUT COVER GIVES A FINISHED APPEARANCE

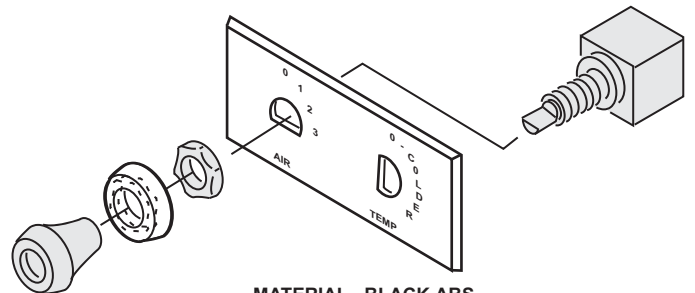

MATERIAL - BLACK ABS

# FASTENERS:

## "QUICK-LOC"

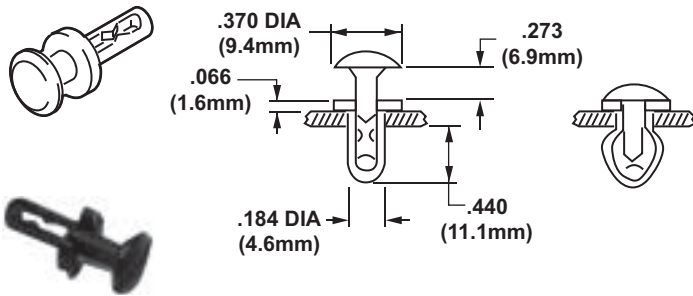

**P.N. 04-1002**

3/16" NYLON "PUSH-IN" FASTENER  
DESIGNED FOR .090 - .190 THK MATERIAL

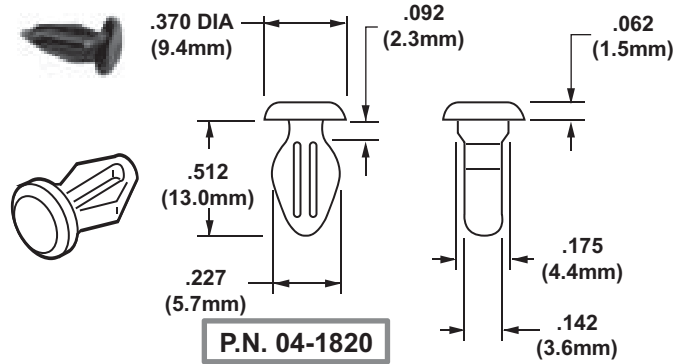

**P.N. 04-1820**

3/16" NYLON "PUSH-IN" FASTENER  
DESIGNED FOR JOINING PLASTIC  
TO METAL

## REGULAR TIE KIT

**P.N. 04-1008**

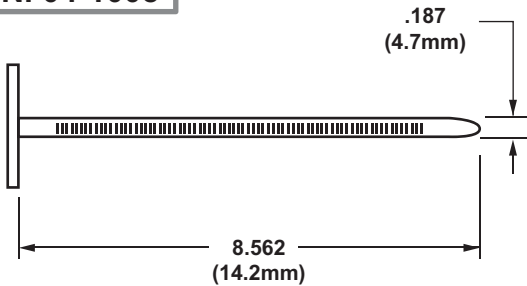

- PACKAGE CONTENTS:**
- 8 - FOAM SPACERS
  - 4 - TIES
  - 4 - FASTENERS
- PACKAGED IN A  
CLEAR PLASTIC BAG

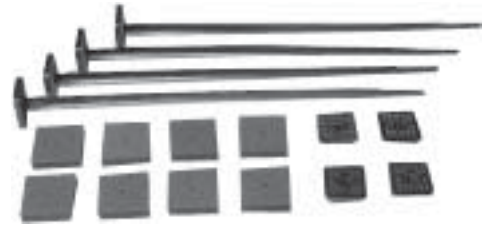

MATERIAL - BLACK NYLON

## FLEX HOSE CLIP

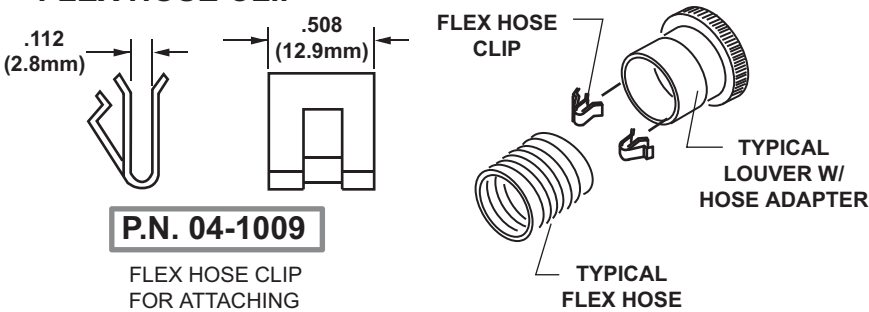

**P.N. 04-1009**

FLEX HOSE CLIP  
FOR ATTACHING  
FLEX HOSE TO HOSE ADAPTER

## PLASTIC ROLLER PICK

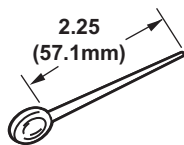

**P.N. 04-1003**

1/8" X 2-1/4" "PUSH-IN" PICK  
LIGHTWEIGHT, WILL NOT RUST  
DESIGNED FOR SECURING FILTER FOAM TO COIL

